

**AXPERT Eazy+**

## SERIES VFD

World's Most Advanced VFD  
User Friendly By Design

400 V System (380 to 480 V),  
0.75 kW (1 HP) to 2000 kW (2700 HP)

500 V System (500 to 600 V),  
30 kW (40 HP) to 1800 kW (2415 HP)

600 V System (601 to 690 V),  
37 kW (50 HP) to 2100 kW (2815 HP)



The **Next Generation Axpert-Eazy+ Series VFD** is the outcome of Amtech's three decades of experience in motor control and automation.

The Low loss, High efficiency Industrial Grade New Series is designed to meet the ever increasing expectations of our customers; deliver highest performance, protection and energy saving without compromising the user friendliness.

It comes with fully configurable I/O and Functional Safety Functions.

Experience the easiness of control and powerful performance.

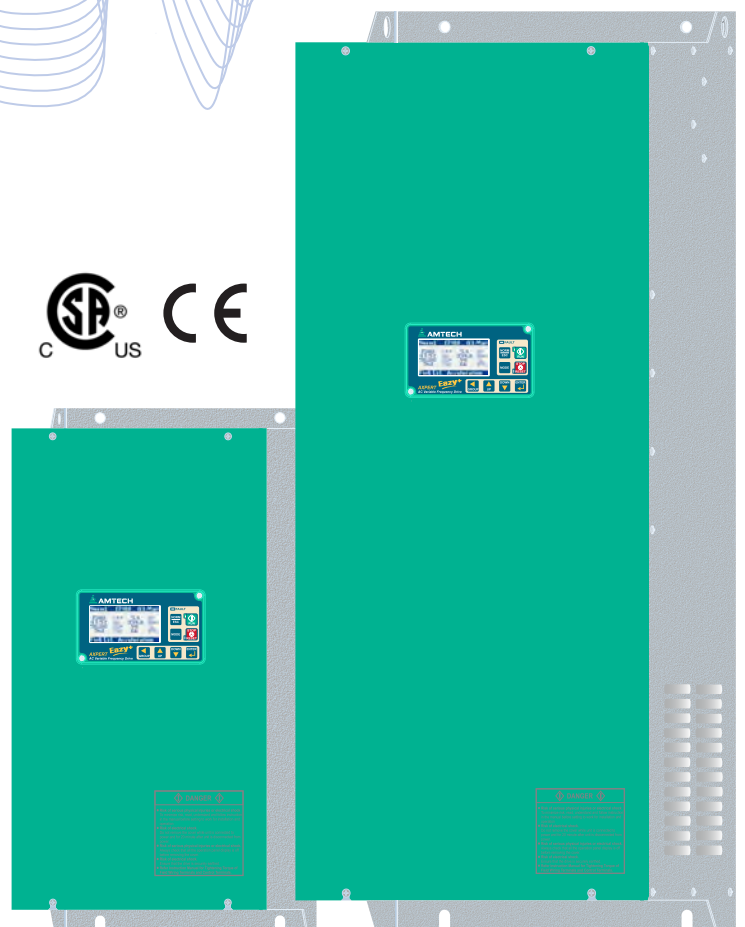



## Easy to INSTALL & COMMISSION

### Compact

The New Series VFD is downsized considerably, up to 52% smaller in volume compare to the previous series and requires less space to install.

**Well-defined terminations** for power and control circuit. All the power terminals are on either left side or bottom side.

**Commissioning Mode** for easy commissioning.

**Debug Mode** for the logic verification without actually rotating the motor.

## Easy to PROGRAM

Shorter programming time, **Application Macro** sets the required parameters as per the application and rating.

**Functional Macros** sets the required parameters and I/O as per the function usage.

Identify the changed parameters at a glance with **Default differ function** and change the parameter from the same menu.

## Easy to PROTECT

**High Speed Digital Signal Controller** protects the drive against abnormal conditions.

**User settable overload function** protects the load against overload conditions.

**Soft stall current limit** reduces the output frequency if the output current exceeds the set level.

**Input and Output Phase Loss** detection prevents overload on other phases.

## Designed for HARSH ENVIRONMENTS

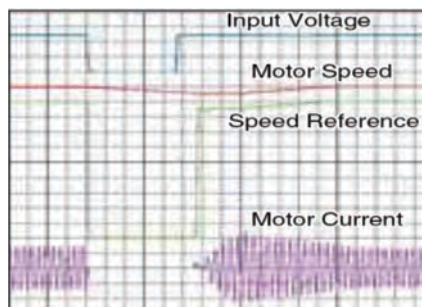

- Immune to power fluctuations
- Wide input voltage range
- Designed for **122 °F (50 °C) ambient temperature**
- State of the art conformal coating on electronic boards as standard to protect printed circuit boards against **3C3 environment**

“  
DRIVE  
FOR  
EVERY  
INDUSTRY

## Easy to MONITOR

IP 65 from front side detachable Digital Operation Panel

**128x64 Graphical LCD Display** with white back light and **Real Time Clock**

8-Key Keypad with 3 status indicating LEDs RUN, STOP and FAULT

Self-explanatory full parameter name in English

Auto Rotation of Norm Screens with settable time

**8 selectable parameters on single screen to monitor critical parameters simultaneously**

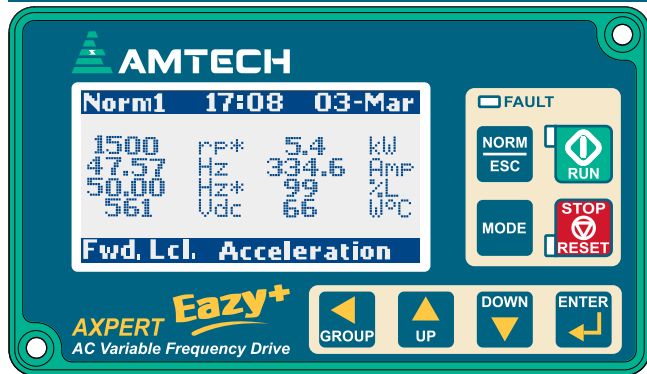

**Easy navigation, self-explanatory functional keys NORM, MODE, GROUP, UP, DOWN, RUN & STOP**

8 parameters (Norm1 & Norm2), 2 parameters (Norm3) and 1 parameter (Norm4) screens

Norm5 screen simultaneously displays start control reference, speed reference and 4 parameters



### Fwd, Lcl. Acceleration

Second screen with 8 selectable parameters, Monitor critical parameters simultaneously



### Fwd, Lcl. Acceleration

Simultaneous display of Start control, Speed reference and 4 Parameters



### Fwd, Lcl. Acceleration

Two parameter screen, Large fonts, Selectable parameters



Fault history with date & time stamp, 8 critical parameters and VFD status at the time of fault



### Fwd, Lcl. Current Lmt

Single parameter screen, Large fonts, Better Readability

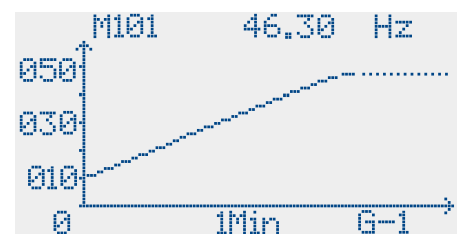

Two Graph-screens G1 & G2, Selectable Parameters and Resolution

## Easy to DIAGNOSE

**Diagnosis Functions** help to pin point the fault

**Fault history**, last 20 faults with time stamp and 8 important operational parameters

**Load Analyzer1** shows user selected parameter Vs time profile in 10% steps, useful for fault analysis (see below screen)

**Load Analyzer2** shows load current Vs time profile for entire service life in 10% step (see below screen)

**Peak Load monitoring** with time stamp and other parameters

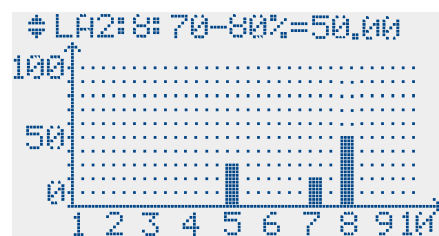
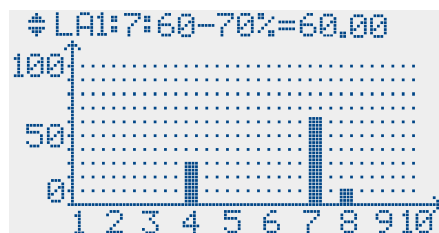

“  
DRIVE  
FOR

DEMANDING  
APPLICATIONS

## Easy to CONTROL

**NextGen** control to deliver highest performance

**In-built PLC** with **Functional Block** Based Programming

Range of **Fully Configurable I/O**

10 Digital Inputs (2 fixed, 8 programmable), +24V operated sink/source and normally open/close selectable, DI8 is configurable as Pulse Input

4 Digital Outputs, Up to +30V operated and normally open/close selectable, DO4 is configurable as Pulse Output

3 Relays, normally open/close selectable

3 Analog Inputs (Two configurable as voltage or current input, one as +/-10 V input)

3 Analog Outputs (Two configurable as voltage or current output, one as +/-10 V output)

2 fixed digital inputs dedicated for **Safe Torque Off (STO)**, the digital output can be programmed for the STO feedback

**32 Configurable Serial Parameters** helps to read 32 parameters in a one go

**PID, Multi-pump, Ring Spinning Frame, Pattern Run** software functions

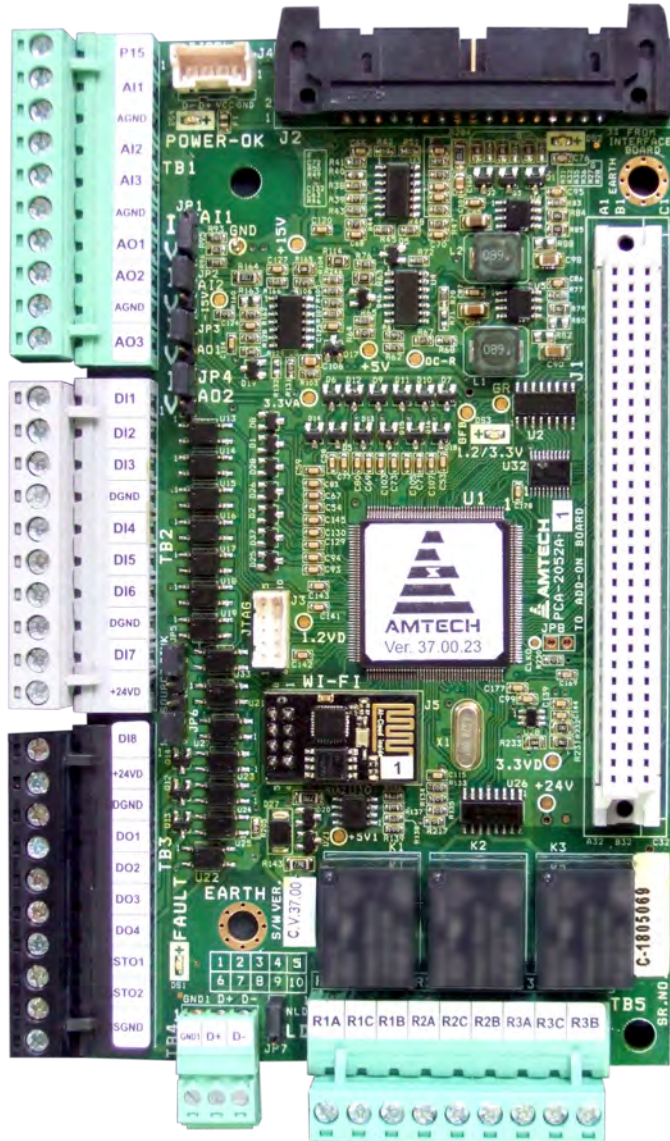

## Easy to MAINTAIN

The cooling fan, one of the common service parts can be easily removed for replacement.

Total Power On Time and Total Run Time provides the information about the drive and machine usage for the monitoring of serviceable parts.

**Predictive maintenance** helps reduce process down time

## Easy to ECONOMIZE

**IE2 Compliant VFD**

**Built-in PID, PLC & application specific software** reduces the peripheral cost.

Built-in **Energy Saving Calculator**

**High-Efficiency operation** mode

Multi-pump control function

Auxiliary Drive control function

## Easy to CONNECT

**RS-485 Modbus Protocol, Wi-Fi** as standard

**Expert-Communicator™ Drive Support Software**

Powerful monitoring and control software for PC for controlling maximum drives at a time.

All parameter reading / writing & monitoring  
Bargraphs / Trend plots / Alarm view

**Mobile Application**

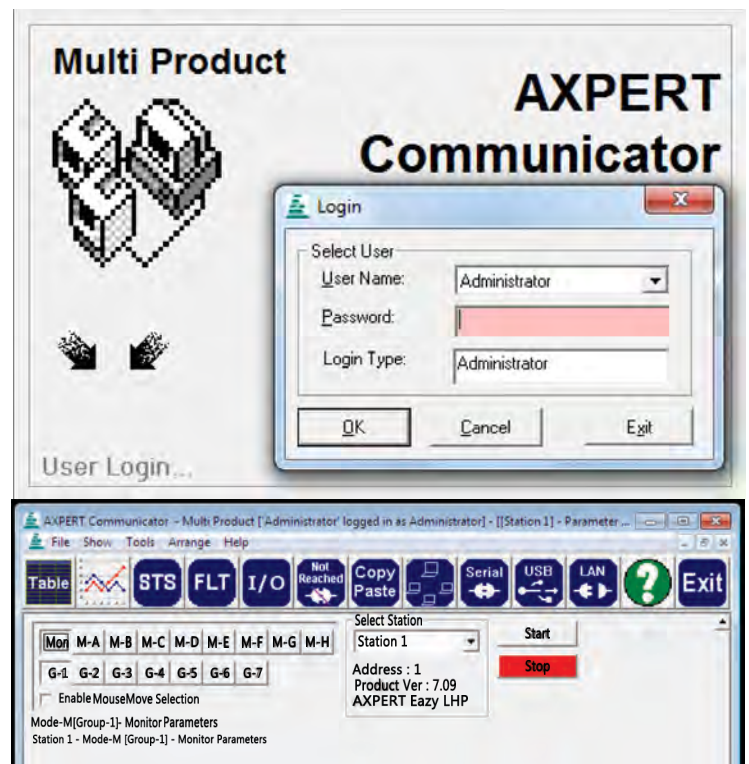

## Option BOARDS

ID	DESCRIPTION
OP01	Line Driver Encoder (5V)
OP04	Ethernet IP + Line Driver Encoder (5V)
OP05	Ethernet IP + HTL Encoder (5...24V)
OP06	ProfiNet + Line Driver Encoder (5V)
OP07	ProfiNet + HTL Encoder (5...24V)
OP08	Ethercat + Line Driver Encoder (5V)
OP09	Ethercat + HTL Encoder (5...24V)
OP10	Modbus TCP + Line Driver Encoder (5V)
OP11	Modbus TCP + HTL Encoder (5...24V)
OP12	DeviceNet + Line Driver Encoder (5V)
OP13	DeviceNet + HTL Encoder (5...24V)
OP14	Profibus-DP + Line Driver Encoder (5V)
OP15	Profibus-DP + Line Driver Encoder (5V) + 8DI + 8DO + 4AI + 3AO + 3RTD
OP16	Line Driver Encoder (5V) + 8DI + 8DO + 4AI + 3AO + 3RTD
OP17	HTL Encoder (5...24V)
OP18	Profibus-DP

## External SYSTEM OPTIONS

**EMI/RFI Filter** helps control equipments run without disturbances

**ACL/DCL** reduces current harmonics up to 38 to 45%

**Active Front-end Converter (AFC), 12-pulse/18-pulse Converter** for low harmonic requirements and IEEE 519 compliance

**DB Unit** and **DB Resistor** with various options

**Load Reactor, dV/dt Filter, Sine Filter and Common Mode Noise Filter** for longer cable lead to reduce the voltage stresses at motor terminals

Refer our **Engineered System** catalog for more details

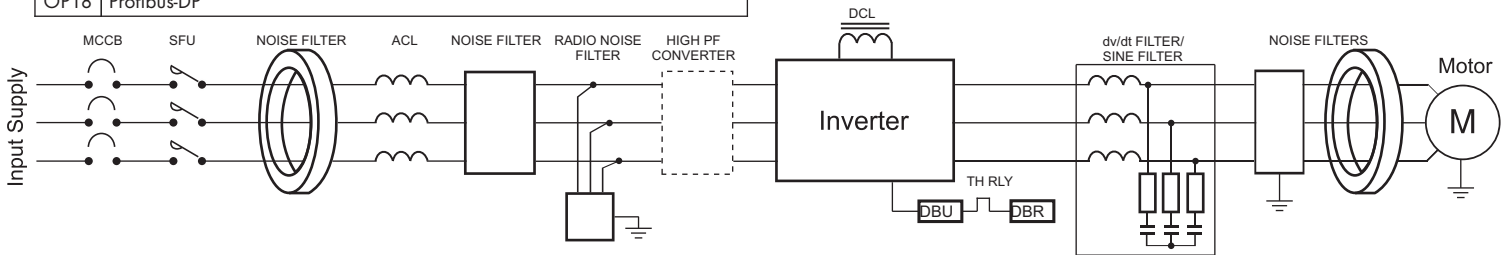

## Connections and TERMINALS

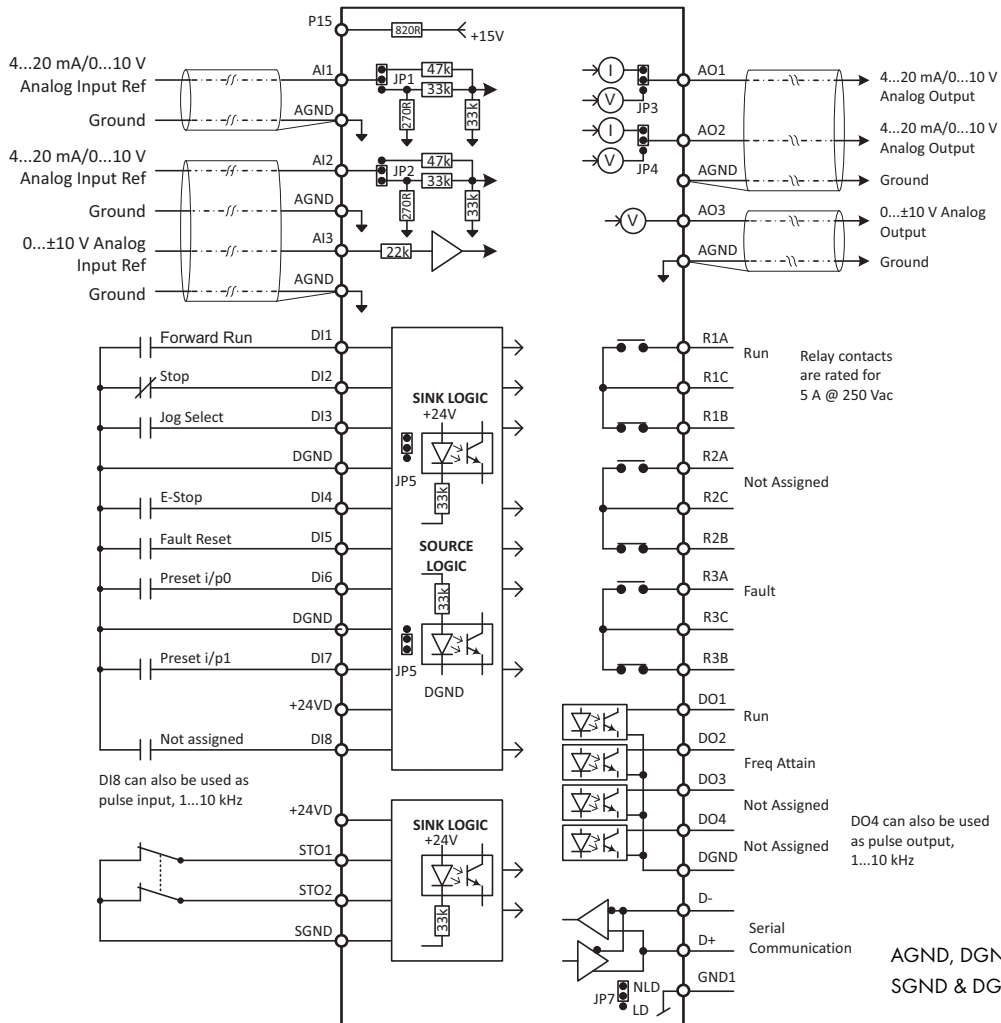

### Control Terminals

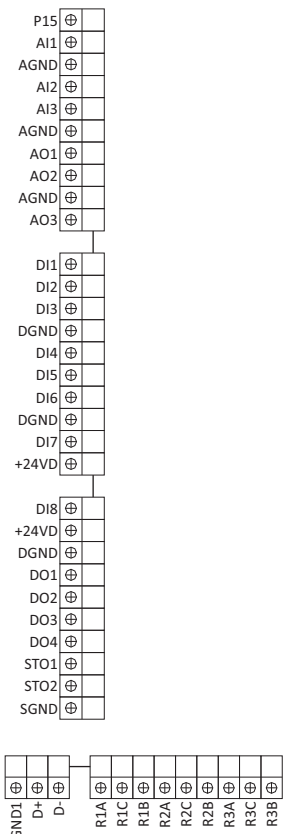

AGND, DGND & GND1 are internally isolated.  
SGND & DGND are internally connected.

Power Rating	Mains supply voltage	-4: 380...480 VAC, 3-Phase, 3-Wire, -15%, +10% -6: 500...600 VAC, 3-Phase, 3-Wire, -15%, +10% -6: 601...690 VAC, 3-Phase, 3-Wire, -15%, +10%
	Mains supply frequency	50 Hz, 60 Hz or 50/60 Hz, +/- 3 Hz
	Output current	Nominal output current available continuously, No overload allowed 120% for 60 seconds, every 5 minutes, Normal Duty (ND) use 150% for 60 seconds, every 5 minutes, Heavy Duty (HD) use Higher overload time during cold start
Control Functions	Control Method	Digital Space Vector PWM Control
	Control Mode	V/F, Closed loop V/F, Sensor less Vector Control, Closed loop Vector Control
	Frequency Range	0.10...599.00 Hz for V/F Control; for high frequency requirement, contact Amtech.
	Frequency Accuracy	Digital references: ±0.01% (-15...50 °C), Analog References: ±0.01% (-15...50 °C)
	Output Frequency Resolution	0.0001 Hz (20-bit)
	Frequency Setting Resolution	0.01 Hz Digital, 0.012 Hz @50 Hz Analog (12-bit)
	V/ Hz Characteristics	2-Preprogrammed patterns, 1-Custom 3-point setting pattern
	Torque Boost	Manual/Automatic Selective: 0...20%
	Acceleration/Deceleration Time	0.1-6,00,000 Seconds, Linear or S-Curve selective
	Start Frequency	Set between 0.10 Hz to 10.00 Hz
	Skip Frequency	Three frequencies can be set, band can be set up to 10.0 Hz
	Slip Compensation	Slip compensation frequency up to 5.0 Hz
	Carrier Frequency <sup>(1)</sup>	Default: 5 kHz, 2...10 kHz up to AMT-0336A-4, Default: 4 kHz, 2...6 kHz for AMT-0375A-4 & higher, 500V and 600V Series.
Operation Specifications	Speed Search Function	Allows the drive to start with rotating machine without damage/tripping.
	Kinetic Energy Buffering	In case of momentary power fluctuations allows the drive to run using the kinetic energy of the load
	Power Loss Carry Through	Up to 5 seconds for smooth operation of system during power loss with no output torque
	DC Braking	DC Braking start frequency 0.1...50.0 Hz, Time: 0...25 seconds, Brake current: 15...150%
	Dynamic Braking	In-built dynamic braking transistor up to AMT-0048A-4
	Frequency / Torque Setting Input	Digital Operation Panel (Keypad) Analog Input: 2 kOhm Potentiometer, Programmable Analog Inputs Digital Input: Static Pot (Frequency Increase/ Frequency Decrease), Preset Speeds (Preset input0, 1 & 2), Pulse Input 1 Serial: RS-485, Wi-Fi and other communication protocols Built-in PLC: PLC Analog output1, 2, 3 & 4
	Auto Restart	Adjustable up to 10 times, selectable for different faults
	PID Controller	Inbuilt PID controller can be used as stand alone
I/O Specifications	Analog Inputs	3 Analog Inputs with settable Gain, Bias, Minimum and Maximum scaling AI1 & AI2: 0...10 Vdc/4...20 mA AI3: 0...±10 Vdc
	Digital Inputs	8 Digital Inputs, Sink/Source and Active Close/Active Open selectable; DI8 can be used as pulse input, 1...10 kHz Programmable options: Not Used, Jog Select, Ramp Select, Preset i/p0, Preset i/p1, Preset i/p2, Freq Increase, Freq Decrease, Aux Drive, Emergency Stop, Fault Reset, External fault1, External fault2, Reverse, Terminal, Ref Select0, Ref Select1, PR Step Skip, PR Step Hold, PR/RSF Reset, PID Bypass, PID Disable, Run, Stop, Drive Enable, PLC input1, PLC input2, PLC input3, PLC input4, PLC input5, PLC input6, PLC input7, PLC input8, Torque mode, Ready1 F/B, Forward Run, Reverse Run, Forward Jog, Reverse Jog and MBRK Answer
	Safety Inputs	Safe Torque Off (STO1 and STO2) inputs to comply with Safety Integrity Level 3 (SIL3)
	Digital outputs	4 Digital Outputs, open collector type, Active Close/Active Open selectable; DO4 can be used as pulse output, 1...10 kHz Programmable options: Not Used, Local, Run, Forward Run, Reverse, Reverse Run, I-Detection1, I-Detection2, Freq Attain, Speed Detect1, Speed Detect2, Acceleration, Deceleration, Aux Drive, Timer Output, Zero Speed, Fault Alarm, PID Up Limit, PID Lo Limit, Temp Alarm, Ready, Ready1, Pump1, Pump2, Pump3, Pump4, Doff-End Alarm, Sleep Mode, Fault, PLC O/P1, PLC O/P2, PLC O/P3, PLC O/P4, PLC O/P5, PLC O/P6, PLC O/P7, PID F/B Upper Limit, PID F/B Lower Limit, Fan Control, MBRK, KEB ON, Overload fault, Overcurrent fault, Earth fault, Over temperature fault, Overvoltage fault, STO1, STO2, STO1 & STO2, On Time1, On Time2 and On Time3
	Potential Free Contacts	3 Relays, 1-NO, 1-NC for 5 A @ 240 VAC Programmable options same as digital outputs
	Analog Outputs	3 Analog Outputs with settable Gain, Bias, Minimum and Maximum scaling AO1 & AO2: 0...10 Vdc / 4...20 mA AO3: 0...±10 Vdc
	Network connectivity	Programmable options: Output frequency, Motor current, Drive current, Output power, Output voltage, DC bus voltage, PID output, Heatsink temperature, PLC AO1, PLC AO2, PLC AO3, PLC AO4, Unipolar torque current, Excitation current, Set frequency, Bipolar torque current, O/P frequency -10 to 10V, Motor and Drive Overload
		Isolated RS-485 for PC Interface with Modbus-RTU protocol and Wi-Fi connectivity as standard, optional protocols are Profibus-DP(Slave), ProfiNet, Ethercat, Ethernet IP, Modbus-TCP, DeviceNet

# Standard SPECIFICATIONS

Display	Display and Keypad unit	Digital Operation Panel 128x64 Graphical LCD with white back light LED, 8-Key Keypad, 3 Status indicating LED for Run, Stop, Fault   Real Time Clock Simultaneous display of 8 selectable monitor parameters Two graph screens with selectable graph signal and resolution Load Analyzer screens   Auto rotation of screens with settable time interval
	Protective Specifications	<p>Protective Function</p> <p>Smooth Operation</p> <p>Diagnosis Functions</p> <p>Fault history</p>
Environment	Installation location	Indoor
	Vibration	As per EN 60068-2-6, Acceleration: 1g, Frequency: 10...150 Hz
	Ambient temperature	5...122 °F (-15...50 °C)
	Storage temperature	-4...158 °F (-20...70 °C)
	Altitude (above sea level)	1000 m (3300 ft) without derating, above this derate 3% per 305 m (1000 ft)
	Relative Humidity	0...95% maximum non-condensing
Enclosure		IP20 (Frame F0...F3); IP00 (F4 onwards), IP20 with option kit (F4 onwards)
Reference Standards		UL 508C, UL 61800-5-1, CSA C22.2 NO. 274-17, IEC 61800-5-1, CE (EN 50178:1997, EN 61800-3:2004+A1:2012, EN 61800-5-1:2007), EN 61800-5-2:2007

At rated load, the overall input power factor is approximately 0.9 with 3% ACL or equivalent DCL and displacement power factor is close to unity (>0.98).

The inverter efficiency is >98% at rated load.

(1) If the default carrier frequency is exceeded, derate the output current. Refer instruction manual for derating..

## Dimension 400V/500V/600V SERIES

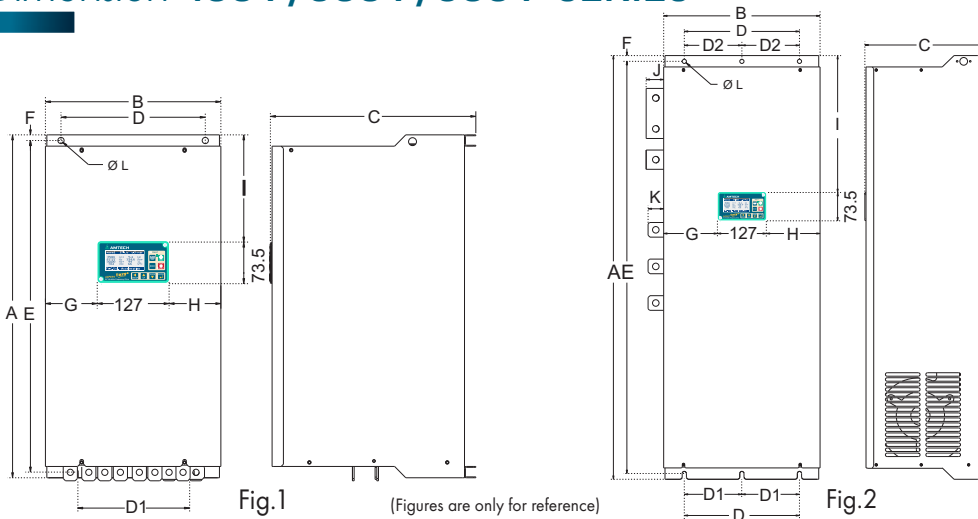

DRIVE FOR ENERGY SAVING

Frame	Fig.	A	B	C	D	D1	D2	E	F	G	H	I	J	K	Ø L
F0	1	325/12.80	183/7.20	191/7.52	118/4.65	118/4.65	-	307.5/12.11	8.5/0.33	28.0/1.10	28.0/1.10	58.5/2.30	-	-	7/0.28
F1	1	325/12.80	183/7.20	218/8.58	118/4.65	118/4.65	-	307.5/12.11	8.5/0.33	28.0/1.10	28.0/1.10	58.5/2.30	-	-	7/0.28
F2	1	335/13.19	228/8.98	218/8.58	163/6.42	163/6.42	-	317.5/12.50	8.5/0.33	50.5/1.99	50.5/1.99	58/2.28	-	-	7/0.28
F3	1	355/13.98	240/9.45	218/8.58	175/6.89	175/6.89	-	337.5/13.29	8.5/0.33	56.5/2.21	56.5/2.21	76/2.99	-	-	7/0.28
F4	1	430/16.93	251.5/9.90	267/10.51	175/6.89	175/6.89	-	411/16.18	9/0.35	62/2.44	62.5/2.46	103/4.06	-	-	10/0.39
F5	1	500/19.69	251.5/9.90	300/11.81	175/6.89	175/6.89	-	481/18.94	9/0.35	62/2.44	62.5/2.46	173/6.81	-	-	10/0.39
F6	1	606/23.86	310/12.20	363/14.29	255/10.04	205/8.07	-	586/23.07	10/0.39	91.5/3.60	91.5/3.60	189.5/7.46	-	-	11/0.43
F7	2	880/34.65	348/13.70	348/13.70	241/9.49	-	-	850/33.46	15/0.59	110.5/4.35	110.5/4.35	299/11.77	41/1.61	44.5/1.75	11/0.43
F8	2	1100/43.31	406/15.98	316.5/12.46	299/11.77	149.5/5.89	149.5/5.89	1070/42.13	15/0.59	139.5/5.49	139.5/5.49	355.5/14.00	55.2/2.17	50.2/1.98	11/0.43
F9	2	1310/51.57	433/17.05	324.2/12.76	326/12.83	163/6.42	163/6.42	1280/50.39	15/0.59	153/6.02	153/6.02	448.7/17.66	55/2.16	50/1.97	11/0.43
F10	*	1157/45.55	685/26.96	479.5/18.88	600/23.62	-	-	870/34.25	20/0.79	285.5/11.24	272.5/10.72	511.6/20.14	-	-	13/0.51
F11	*	1136/44.72	974/38.35	503.5/19.82	880/34.64	-	-	853/33.58	20/0.79	580.5/22.85	266.5/10.49	306.3/12.06	-	-	13/0.51

\* Contact AMTECH or nearest dealer for the dimension information of higher rating models.

# Standard SPECIFICATIONS (400V SERIES)

Model (AMT-XXXXA-4)	Frame	Weight	Nominal Input Voltage 3-Phase, 460 Vac						Airflow (m3/h)
			Output Rating <sup>(1)</sup>						
			No Overload Rating		Normal Duty Rating		Heavy Duty Rating		
kg/lb	A	HP	A	HP	A	HP			
-002A6-4	F0	6.7/14.8	2.5	1	2.4	1	2.4	0.75	204
-003A3-4	F0	6.7/14.8	3.2	1.5	3	1.5	2.5	1	204
-0004A-4	F0	6.7/14.8	3.8	2	3.6	2	3.2	1.5	204
-005A8-4	F0	6.7/14.8	5.5	3	5.2	3	4.5	2	204
-0008A-4	F0	6.7/14.8	7.6	4	7	4	5.5	3	204
-0010A-4	F0	6.7/14.8	9.5	5	9	5	7.6	4	204
-0014A-4	F0	6.7/14.8	13	7.5	12	7.5	10.5	5	204
-0018A-4	F1	8.1/17.9	17	10	16	10	13	7.5	204
-0025A-4	F2	9.0/20.3	24	15	23	15	20	10	204
-0033A-4	F2	9.7/21.4	31	20	29	20	25	15	204
-0039A-4	F3	10.9/24.0	37	25	35	25	31	20	204
-0048A-4	F3	10.9/24.0	45	30	43	30	37	25	204
-0065A-4	F4	18.5/40.8	62	40	59	40	45	30	204
-0077A-4	F4	18.5/40.8	74	50	69	50	62	40	204
-0095A-4	F5	23.5/51.8	91	60	85	60	74	50	356
-0115A-4	F5	23.5/51.8	110	75	105	75	91	60	356
-0155A-4	F6	41/90.4	145	100	140	100	110	75	880
-0190A-4	F6	41/90.4	180	125	165	125	145	100	880
-0225A-4	F6	41/90.4	215	150	205	150	180	125	880
-0260A-4	F7	61.8/136.3	245	200	235	200	215	150	1200
-0336A-4	F7	63.2/139.4	320	250	304	250	245	200	1200
-0375A-4	F8	88.2/194.5	355	275	342	275	320	250	1200
-0415A-4	F8	88.2/194.5	395	300	375	300	355	275	1200
-0445A-4	F8	88.2/194.5	425	350	405	350	390	300	1200
-0510A-4	F8	88.2/194.5	485	400	460	400	405	350	1200
-0590A-4	F9	115/253.6	560	450	545	450	465	400	1200
-0660A-4	F9	115/253.6	610	500	590	500	530	450	1200
-0785A-4	F10	154/339.5	745	550	710	550	610	500	2400
-0850A-4	F10	154/339.5	810	600	770	600	710	550	2400
-0925A-4	F10	154/339.5	880	700	835	700	770	600	2400
-1040A-4	F11	208/458.5	990	800	940	800	835	700	3600
-1175A-4	F11	208/458.5	1115	900	1065	900	940	800	3600
-1265A-4	F11	208/458.5	1200	1000	1145	1000	1020	900	3600
-1540A-4	F12	*	1410	1200	1370	1200	1200	1000	9600
-1780A-4	F12	*	1640	1400	1560	1400	1370	1200	9600
-1900A-4	F13	*	1800	1500	1700	1500	1560	1400	14400
-2100A-4	F13	*	2000	1600	1900	1600	1700	1500	14400
-2300A-4	F13	*	2185	1700	2080	1700	1900	1600	14400
-2650A-4	F14	*	2450	1900	2350	1900	2000	1700	15600
-2900A-4	F14	*	2650	2100	2500	2100	2350	1900	15600
-3260A-4	F15	*	2950	2500	2800	2500	2500	2100	16800
-3460A-4	F15	*	3250	2700	3080	2700	2800	2500	16800

(1) The maximum applicable motor output is given for a standard induction motor.  
\* Contact Amtech for weight and dimension details.



## Standard SPECIFICATIONS (500V & 600V SERIES)

Model (AMT-XXXXA-6)	Frame	Weight	Input Voltage 500...600 V (Nominal 575 V)						Input Voltage 601...690 V (Nominal 690 V)					
			Output Rating <sup>(1)</sup>						Output Rating <sup>(1)</sup>					
			No Overload Rating		Normal Duty Rating		Heavy Duty Rating		No Overload Rating		Normal Duty Rating		Heavy Duty Rating	
			kg/lb	A	HP	A	HP	A	HP	A	HP	A	HP	A
-0048A-6	F6	41/90.4	48	40	46	40	39	30	48	50	46	50	39	40
-0056A-6	F6	41/90.4	56	50	54	50	46	40	56	60	54	60	46	50
-0075A-6	F6	41/90.4	75	60	72	60	56	50	75	75	72	75	56	60
-0090A-6	F6	41/90.4	90	75	87	75	75	60	90	100	87	100	75	80
-0115A-6	F6	41/90.4	115	100	110	100	90	80	115	125	110	125	90	100
-0140A-6	F6	41/90.4	140	125	135	125	115	100	140	150	135	150	115	125
-0155A-6	F7	63/138.9	155	150	150	150	135	125	155	200	150	200	135	150
-0182A-6	F7	63/138.9	182	200	175	200	155	150	182	250	175	250	155	200
-0221A-6	F7	63/138.9	221	250	215	250	182	200	221	300	215	300	182	250
-0300A-6	F8	90/198.4	300	300	290	300	240	250	300	400	290	400	240	300
-0355A-6	F8	90/198.4	355	400	345	400	295	300	355	450	345	450	295	400
-0398A-6	F9	115/253.6	398	450	387	450	345	400	398	500	387	500	345	450
-0430A-6	F9	115/253.6	430	500	426	500	387	450	430	550	426	550	387	500
-0470A-6	F10	148/326.3	470	550	455	550	426	500	470	600	455	600	426	550
-0553A-6	F10	148/326.3	553	600	537	600	482	550	553	700	537	700	482	600
-0605A-6	F11	208/458.5	605	700	580	700	537	600	605	750	580	750	537	700
-0685A-6	F11	208/458.5	685	750	662	750	580	700	685	900	662	900	580	750
-0750A-6	F11	208/458.5	750	900	730	900	662	750	750	1000	730	1000	662	900
-0850A-6	F11	208/458.5	850	950	840	950	750	900	850	1200	840	1200	750	1000
-0970A-6	F12	*	970	1000	950	1000	850	950	970	1400	950	1400	850	1200
-1090A-6	F12	*	1090	1400	1060	1400	950	1000	1090	1500	1060	1500	950	1400
-1170A-6	F12	*	1170	1500	1150	1500	1060	1400	1170	1600	1150	1600	1060	1500
-1360A-6	F13	*	1360	1600	1330	1600	1150	1500	1360	1700	1330	1700	1150	1600
-1520A-6	F13	*	1520	1700	1440	1700	1330	1600	1520	2000	1440	2000	1330	1700
-1700A-6	F14	*	1700	2000	1680	2000	1440	1700	1700	2400	1680	2400	1440	2000
-1850A-6	F14	*	1850	2200	1755	2200	1680	2000	1850	2500	1755	2500	1680	2400
-2300A-6	F15	*	2300	2500	2210	2500	1755	2200	2300	2900	2210	2900	1755	2500

- 1) If the default carrier frequency is exceeded, derate the output current. Refer instruction manual for derating.
- 2) The inverter efficiency is >98%. The input power factor is approximately 0.9 when 3% rating of ACL/DCL is used.
- 3) The output current indicates the total effective value including the higher harmonics.
- 4) The HP shown is maximum applicable motor output for a 4-pole standard induction motor.

## IU/DU Concept for HIGH POWER VFD

Amtech offers VFD up to 2100 kW (2815 HP) power rating.

The high power rating models adopt paralleling of modular **Diode Units (DU)** and **Inverter Units (IU)** as shown in the figure and are assembled in a panel.

Number of IU/DU depends on VFD rating. Up to six Inverter Units can be connected in parallel.

The DU/IU are easily removable in case of maintenance.

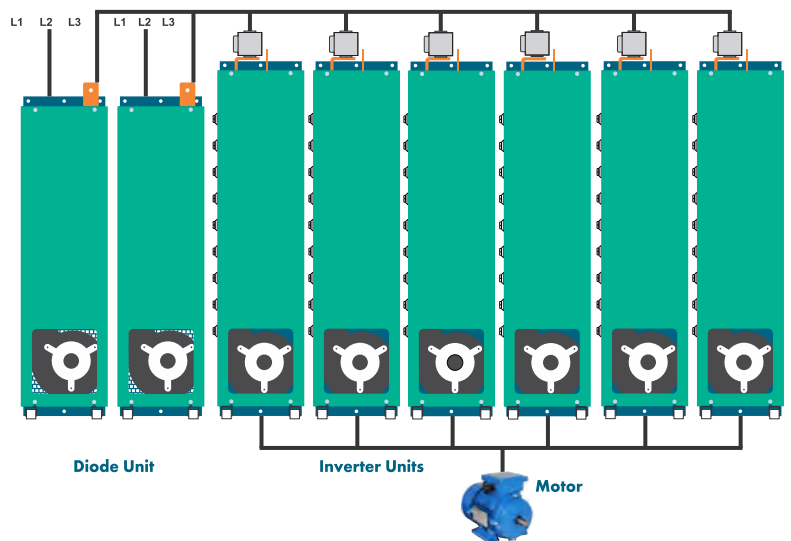

## Application INDUSTRIES

Expert-Eazy+ Series VFD is a perfect solution for soft start, speed regulation, energy saving & intelligent control of induction motor. For demanding applications like crane, conveyor, stacker/reclaimer, centrifuge etc.. it delivers unmatched performance.

### Water & Waste Water



Pressure Blower, Sewage Pump, Cleaning Water Pump, Reclaimed Water Pump, FD Fan, ID Fan, Lifting Pump, Pressure Pump, DM Water Supply Pump, ETP Pumps, Odour Fan, Raw Water Pump, Decanter Centrifuge

### Oil & Gas



Drilling Rig, Mud Pump, Submersible Pump, Progressive Cavity Pump, Artificial Lift (Pump Jack), Pipeline Transportation Pump, Submerged Pump, Compressor, Pressure Blower, Water Injection Pump, Feed Water Pump for Offshore Oil Platform

### Cement & Aggregate



Kiln Draft Fan, Coal / Raw Mill Drive, Dust Removal Fan, Cooling Fan, Stone Crusher, Rotary Kiln Transmission, Stacker Reclaimer, Cranes, Feeder, Conveyor, Cooler Fan, Preheater Fan, Baghouse Fan, ESP Fan, Circulating Dust Collector Fan, Roto Packer Machine, Roller Press Mill, Air Compressors

### Pulp & Paper



Complete Drive & Automation Solutions for Pulp & Paper Mill; VFD for Sectional Paper Machine, Pulp Mill, Rewinder, Process Fans & Pumps, Boiler, Sheet Cutting Machine, Printing & Packaging Machines

### Coal mines & Minerals



Descaling Pump, Feeding Pump, Drainage Pump, Mud Pump, Stirring Pump, Ball Mill, Slurry Pump, Kiln Transmission, Conveyer, Clean Water Pump, Ventilation Fan, Crusher, Bucket Elevator

### Thermal power, Hydro power



ID Fan, FD Fan, FW Pump, PA Fan, SA Fan, Slurry Pump, Cooling Tower Pump & Fan, Condensate Water Pump, Air Compressor, Coal Mill, Conveyor, Wagon tippler, Cranes

### Chemical & Pharmaceutical



Gas Blower, Water Delivery Pump, Soft Water Pump, Chlorine Compressor, Pressure Pump, Axial Flow Pump, Stirrer, Agitator, Fermentator, Dosing Pumps

### Steel & Metal



Blast furnace Fan, Compressing Blower, Compressor, Water-delivery Pump, Descaling Pump, Pusher/Charging/Transfer Car, ID Fan, FD Fan, Stacker/Reclaimer, Crane, Primary/Secondary Dust Removal Blower, Rolling Mills, Roller Table, Wire/Sheet Drawing Machine, Apron Feeder, Wagon Tippler, Downhill Conveyor, Kiln, Washer Pumps, Bellet Heaters, Cranes

### Sugar



Complete Drive & Automation Solutions for Sugar Mill; Can Unloader, Feeder Table, Cane Carrier, Cutter, Fiberizer, Rack Elevator, Mill Drive, Juice Pump, PAN Circulator, Sugar Centrifugal, Bagasse Carrier, ID/FD Fan, FW Pumps, Packing Plant, Refinery & Distillery

and many other industries like food & beverages, textile, automobile, fertilizer and manufacturing units.

## Application Macros

Conveyor  
Compressor

Centrifuge  
Fan

Fermentor  
Crane / Hoist

Pump  
Pump Jack (Artificial Lift)

# User selectable FUNCTIONS

## PID Control

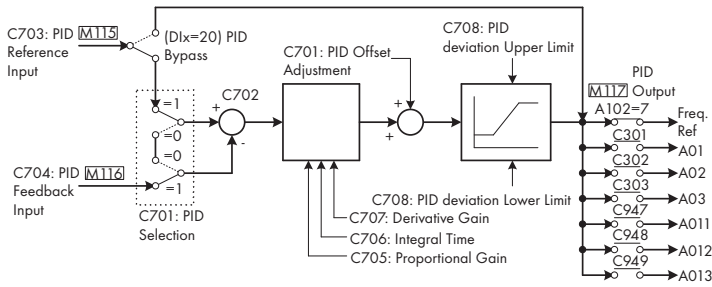

## Auxiliary Drive Motor Control

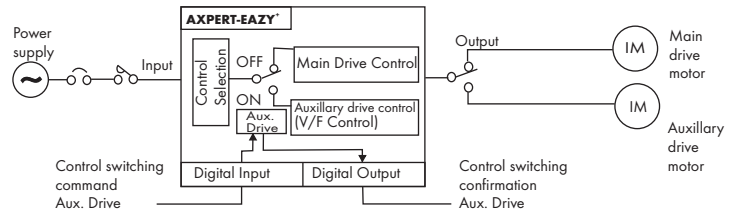

## Multi-pump Control

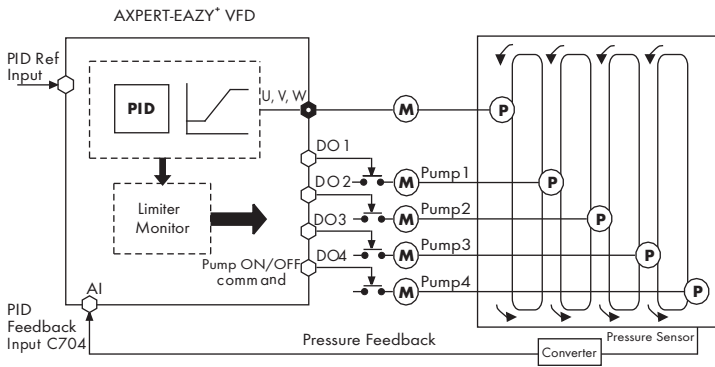

## PLCT & Speed Search

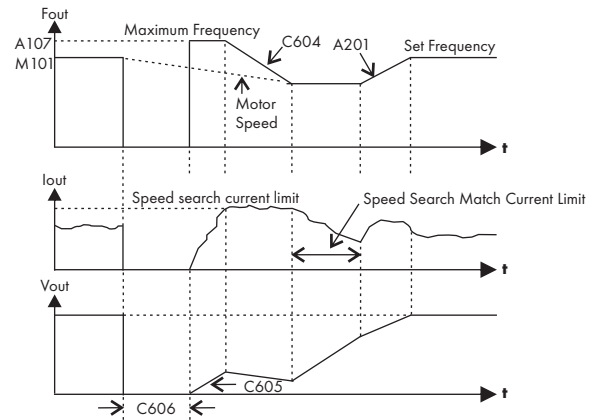

## Pattern Run & RSF

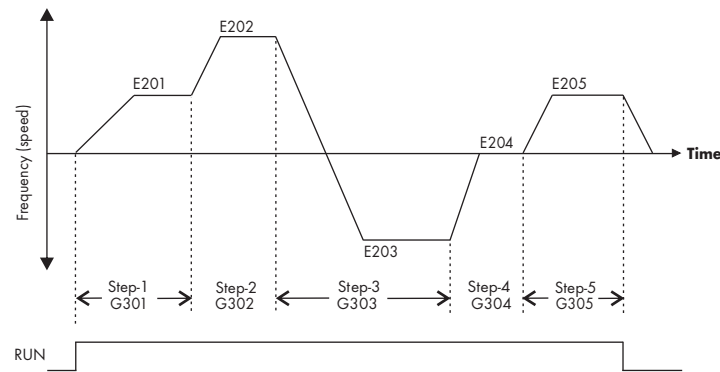

## KEB (Kinetic Energy Buffering)

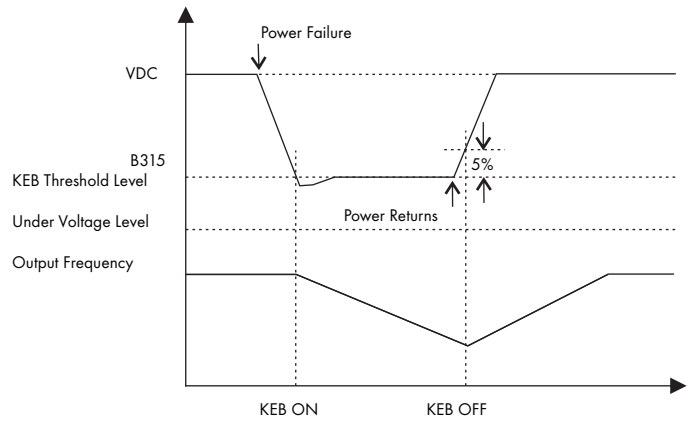

## External Brake Control

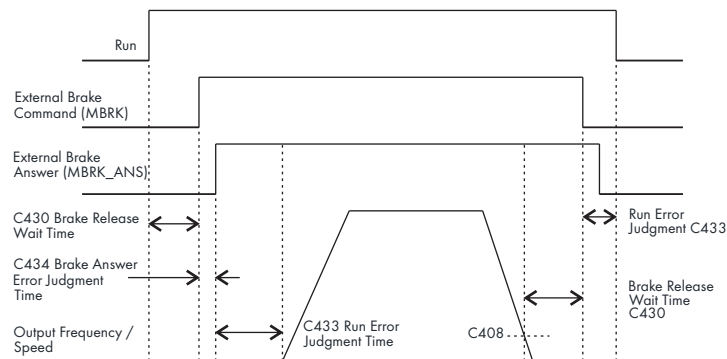

## Math Operation

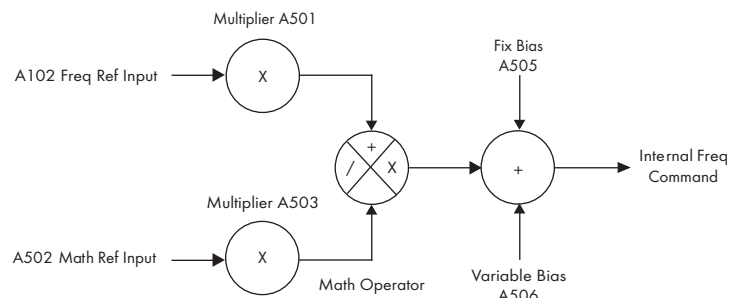

## OUR OTHER OFFERINGS



### AXPERT-OPTI torque ELECTRONIC SOFT STARTER

**AXPERT-OPTI torque - Bypass series**, The high performance electronic soft starters offer advanced technology in motor start, stop, protection, monitoring, diagnostics and automation.

**Models:**

15...1065 A,  
3.7...1000 kW (5...1340 HP)  
200...690 V Supply Voltage

**Features:**

- Three starting modes - Voltage ramp - Current ramp - Torque ramp
- Soft stop facility
- Configuration modes - Inline - Bypass - Inside Delta
- Wide range class 2 to 30 electronic overload
- Built-In Energy Meter
- Full Motor Protection
- Digital Operation Panel 5 digit, 7-segment LED display (Ip65)
- RS-485 Modbus Communication (Standard)

**Applications :**

- Air Compressor
- Pumps and Fans
- Conveyors/Escalators
- Ball Mills, Aggitators
- Pulpers, Grinders



### ADAPT SYSTEM PUMP JACK SOLUTION

Amtech Drives offers the ultimate solution in **SRP (Sucker Rod Pump) control**, the most common forms of reciprocating artificial lift system employed by Oil and Gas companies worldwide. Amtech offers solutions in all the processes of Upstream, Midstream and Downstream in Oil & Gas industry.

**Models:**

400 V: 5 to 100 HP (3.7 to 75 kW)

**Features:**

- Factory-tested Integration
- Simplified setup
- Smooth starting & operation of system
- Lower impact on piping/valve system, longer equipment life and less maintenance
- Unique algorithm for torque control and no need of braking resistors

**Applications:**

- Oil well pump jack



### ENGINEERED SYSTEMS

Our vertically integrated engineered systems assures seamless co-ordination between individual components in our complete packaged solutions.

The packages comprise VFD modules with customer specific switchgear & protection, enclosure requirements and cooling arrangements. The seamless integration guarantees that performance specifications are adhered to as per the ratings, enclosure types, environmental issues and power supply conditions.

**Advantages:**

- Global compliances UL, cUL, CSA and CE
- Normal duty & heavy duty ratings
- UL panel shop
- Energy efficient systems
- Can be built to your specification

**Customized Applications:**

- Bypass Solutions for Critical Applications
- Redundant System
- Low Harmonic Solutions