

AXPERT OPTI torque

The High Performance
Electronic Digital Soft Starter -
Internal Bypass Series



**15...1065 A, 5...1340 HP (3.7...1000 kW)
200...690 V Supply Voltage**



Features

- 3-Phase control
- Universal control supply 90...270V AC 50/60Hz
- Most advanced integrated electronic motor over load and over current protections
- Wide range class 2 to 30 electronic overload
- In-built Energy Meter, displays kWh & MWh
- In-line (3-wire) / Inside Delta (6-wire) operating modes
- Motor PTC connection for motor over temperature protection
- Conformal coating on all circuit boards (PCBs) as standard to protect against 3C3 environment
- Commissioning mode for easy commissioning
- RS-485 Modbus Communication with Axpert-Communicator software for remote monitoring
- Fully Configurable Analog and Digital Inputs / Outputs
- Stores last 20 Diagnostic faults with of 8 key operational parameter values and status at the time of fault
- Senses current in all three phases and provides Current, Voltage & Power information; protection even in bypass mode
- Energy efficient design - Cooling fan control as per heat-sink temperature. This will increase fan life and also reduce the power consumption
- Digital Operation Panel 5 digit, 7-segment LED display (IP65) with 2 decimal points, Unit indication, Start Mode, Start control, Bypass and Starter's status LEDs display, 9-Key Keypad, 3-LED for Run, Stop, Fault
- In-built PLC Function for logical operations and interlocking, with Axpert-Drive logic programming tool for easy programming

Standard SPECIFICATIONS

Power Source		4: 200...480 VAC or 6: 200...690 VAC, 3-Phase, 3-Wire, 50/ 60 Hz																									
External Control Supply		1-Phase, 50/60 Hz, 90...270 V or 115 V or 230 V (Refer order code for control supply detail)																									
Tolerance		Voltage tolerance: -15%, +10%, Frequency tolerance: ±5%																									
AMT-OT-iB-XXXXA-4/6-X-X		0015	0023	0028	0034	0044	0052	0065	0078	0087	0096	0125	0160	0180	0215	0250	0320	0360	0414	0477	0515	0600	0720	0832	0900	0960	1065
Max applicable motor line current (Inline) (A) - Standard Duty		15	23	28	34	44	52	65	78	87	96	125	160	180	215	250	320	360	414	477	515	600	720	832	900	960	1065
Max applicable motor line current (Inside Delta) (A) ¹ - Standard Duty		25	40	48	58	76	89	112	134	150	166	216	276	311	371	432	553	622	716	825	890	1038	1245	1439	1557	1660	1842
Control	Control system	Digital 32-bit Digital Signal Controller																									
	Network connectivity	Supports RS-485 Modbus as standard, Profibus-DP (slave), DeviceNet, CANopen, Ethernet, ControlNet are optional.																									
Operation Specifications	Current feedback & Electronic OLR	Motor current: Adjustable up to 30 % of unit current										I-Trip Level: 100...800% of full load motor current					I-Limit Level: 100...600% of full load motor current										
		Low Level: 0...100% of full load motor current										I-Low Time: 0...20 minutes					I-Limit Time: 10...60 sec										
	Digital Inputs	4-Programmable Sequence Inputs, Sink / Source changeable, max 5 mA each Programmable between 17 different options: Not Used, Terminal, Jogging, External Fault, Fault Reset, Bypass Contactor, Main Contactor, E-Stop, Ramp Hold, Reverse Contactor, Run, Stop, Motor PTC, PLC I/P 1...4																									
	Potential Free Contacts	3-Programmable relays:										1-Relay: 1-NO for 5 A @ 240 VAC					2-Relay: 1-NO, 1-NC for 5 A @ 240 VAC										
		Programmable between 41 different options: Not Used, Ready, Run, Top of Ramp, Fault Alarm, I-Limit Alarm, Low Current Alarm, High Current Alarm, Temp Alarm, Reverse Contactor, Main Contactor, External Fan Control, Over Current Fault, Under Current Fault, I-Unbalance Fault, Overload Fault, Over Voltage Fault, Mains Off Fault, Phase Loss Fault, External Fault, Emergency Fault, Motor PTC Short Fault, Motor PTC Over Temperature, Power Not OK, Bypass Relay Fault, EEPROM Fault, Ground Fault, Phase Direction Fault, Over Freq Fault, Under Freq Fault, Thermistor OT Fault, Thermistor NC Fault, Thermostat NC Fault, Firing Fault, Thermistor Short Fault, SCR Short Fault, Watchdog Fault, PLC O/P 1...3																									
	Analog Outputs	2-Programmable analog current outputs AO1 & AO2: 4...20 mA with settable gain, bias, minimum and maximum scaling, 12-bit Programmable between 7 different options: Output Current, Active Power, Reactive Power, Power factor, Motor torque, Heat sink temperature, Motor PTC, PLC Analog output 1 and 2																									
	Motor PTC Feedback	One or three Motor PTC can be connected for motor over temperature protection																									
Operation Specifications	Start Mode	V-Ramp Start		Dual Ramp Selection					V-Ramp Up Time: 1:1...240 sec					Pedestal-1: 25...90%													
		Kick Time: 0...2.0 sec		Kick Voltage: 0...90%					Target: 25...100%																		
		I-Ramp Start		I-Ramp Up Time: 1...60					Initial Current: 100...300%					I-Proportional Gain: 0.01...2.00													
	Stop Mode	T-Ramp Start		T-Ramp Up Time: 1...240 sec					Initial Torque: 1...250%					Torque Limit: 1...250%													
		T-Proportional Gain: 0.1...2.0																									
		V-Ramp Stop		V-Ramp Down Time: 1...240 sec					Initial Voltage: 100...25%					Final voltage: 70...25%													
	Control Mode	Brake Stop		Brake Ramp Time: 0.1...20.0 sec					Brake Voltage: 25...100%					Brake Time: 1...240 sec													
T-Ramp Stop		T-Ramp Down Time: 1...240 sec					T-Integral Time: 0.01...100.00																				
Coast to stop																											
Display	Display and Keypad module (Standard)	Digital Operation Panel 5 digit seven segment LED display with 2 decimal points, Unit indication, Start Mode, Start control, Bypass and Starter's status LEDs display, 9-Key Keypad, 3-LED for Run, Stop, Fault. 13 predefined normal parameter display; Can be mounted on panel door with optional extension cable.																									
	Graphical Display and Keypad unit (Optional)	Digital Operation Panel 128x64 Graphical LCD with white back light LED, 9-Key Keypad, 3-Status indicating LED for Run, Stop, Fault Real Time Clock Simultaneous display of 8 selectable monitor parameters Two graph screens with selectable graph signal and resolution Auto rotation of screens with settable time interval Can be mounted on panel door with optional extension cable																									
Start Duty	Overload Duty	10 equally spaced starts per hour at 350% current, each of 30 seconds duration, i.e. 30 seconds on time and 330 second off time. For models -0720A to -1065A, 6 equal start.																									
		10 equally spaced starts per hour at 500% current, each of 15 seconds duration, i.e. 15 seconds on time and 345 second off time. For models -0720A to -1065A, 6 equal start.																									
Protection	Utilization Category	10 equally spaced starts per hour at 500% current, each of 30 seconds duration, i.e. 30 seconds on time and 340 second off time. For models -0720A to -1065A, 6 equal start. Contact AMTECH for derating information.																									
		AC53a or AC53b																									
Environment	Diagnostic fault and protection	Over current fault					Over voltage fault					Temperature fault					Reverse contactor fault										
		Over load fault					SCR Short fault					Phase direction fault					Main contactor fault										
		Ground fault					Over frequency fault					I-Unbalance fault					Bypass contactor fault										
		Phase Loss fault					Under frequency fault					Firing fault															
		Mains off fault					Motor PTC fault					Watchdog fault															
Reference Standards	Installation Location	Indoor																									
	Ambient Temperature	5...131 °F (-15...55 °C), for model -0414A-X and above, derate 2%/°F above 122 °F (50 °C)																									
	Storage Temperature	-4...158 °F (-20...70 °C)																									
	Altitude (above sea level)	3300 ft (1000 m) without derating, above this derate 3% per 1000 ft (305 m) up to 4000 m																									
	Humidity	0...95% max non condensing																									
Enclosure	IP20 up to 110A model, after that IP00 (other can be provided on demand)																										
Reference Standards		UL 508, UL 60947-4-2, CSA C22.2 60947-4-2, IEC 60947-4-2, IEC 60947-1, CE (EN 60947-4-2), IEC 60529																									

1: Contact Amtech for Inside Delta option up to 360 A in AMT-OT-iB series above 480V input.

Typical Connection Diagram

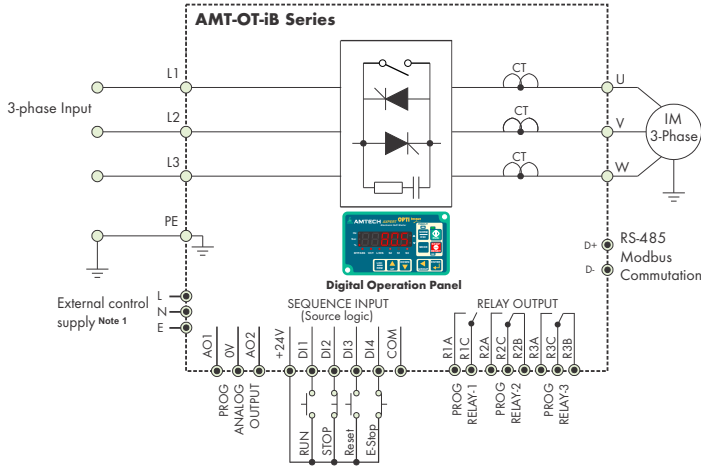

In-line configuration

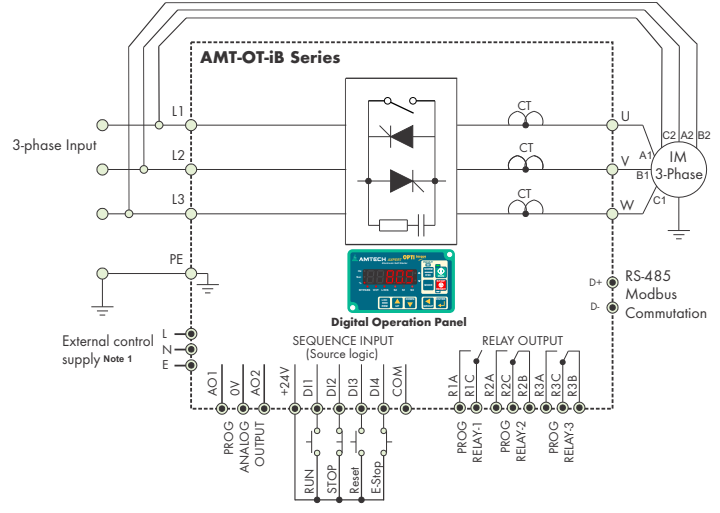

Inside Delta configuration

Note:

1. Control supply 1-phase, 50/60 Hz, 90...270 VAC or 115/230 VAC to be provided by customer. Refer ordering code.

Display Options

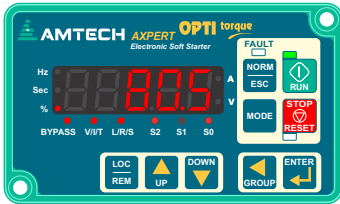

LED Display (Standard)

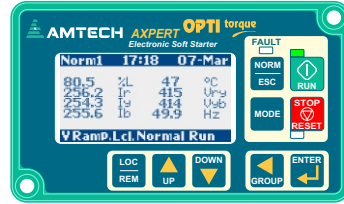

Graphical LCD Display (Optional)

Model Number

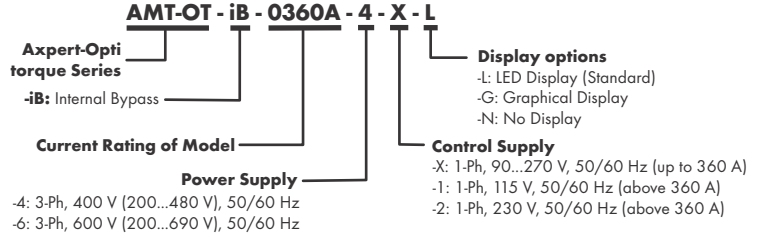

Outline Dimensions

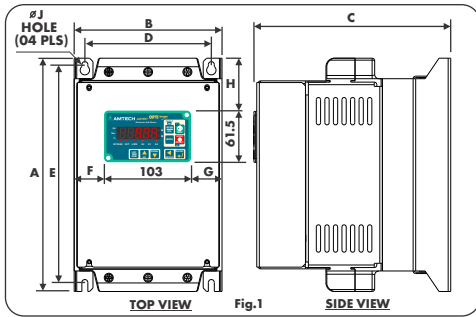

Fig.1

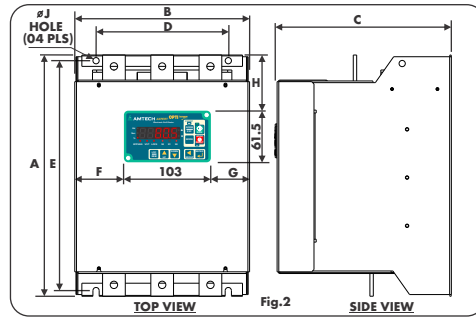

Fig.2

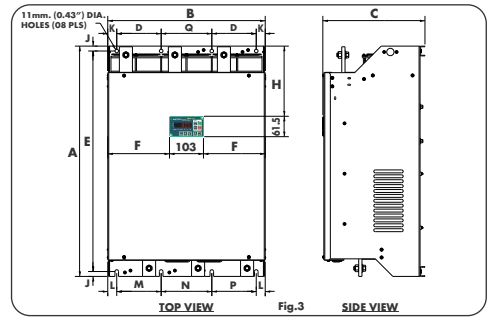

Fig.3

Model	Dimensions in mm (Inch)										Weight in kg (lb)
	A	B	C	D	E	F	G	H	J		
AMT-OT-iB-0015A, -0023A, -0028A, -0034A, -0044A, -0052A, -0065A, -0078A, -0087A, -0096A, -0110A											
Fig.1	273 (10.75)	173 (6.81)	230 (9.05)	148 (5.83)	255 (10.04)	35 (1.38)	35 (1.38)	61.5 (2.42)	7 (0.28)	6.7 (14.8)	
AMT-OT-iB-0125A, -0160A, -0180A, -0215A											
Fig.2	393 (15.47)	308 (12.13)	274.5 (10.81)	233 (9.17)	373 (14.69)	102 (4.02)	102 (4.02)	111 (4.37)	11 (0.43)	19 (41.9)	
AMT-OT-iB-0250A, -0320A, -0360A											
Fig.2	425 (16.73)	308 (12.13)	310.5 (12.22)	233 (9.17)	405 (15.94)	102 (4.02)	102 (4.02)	120 (4.72)	11 (0.43)	23 (50.7)	

Model	Dimensions in mm (Inch)														Weight in kg (lb)
	A	B	C	D	E	F	H	J	K	L	M	N	P	Q	
AMT-OT-iB-0414A, -0477A, -0515A, -0600A															
Fig.3	705 (27.7)	482 (19.0)	312.5 (12.3)	136 (5.3)	675 (26.5)	189.5 (7.4)	214 (8.4)	15 (0.6)	25 (1.0)	25 (1.0)	136 (5.3)	155 (6.1)	136 (5.3)	155 (6.1)	67 (147.7)
AMT-OT-iB-0720A, -0832A, -0900A, -0960A, -1065A															
Fig.3	830 (32.7)	578 (22.7)	358.5 (14.1)	173 (6.8)	800 (31.5)	237.5 (9.3)	316 (12.4)	15 (0.6)	25 (1.0)	25 (1.0)	173 (6.8)	177 (7.0)	173 (6.8)	177 (7.0)	112 (246.9)

Contact Amtech for dimension detail

Our Other Offerings

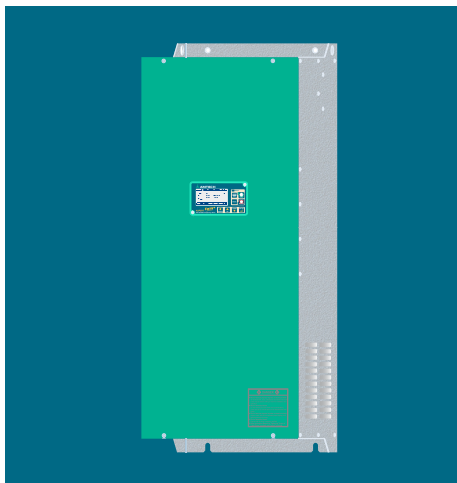

AXPERT Eazy+ SERIES VFD

The **Next Generation Axpert-Eazy+ Series VFD** is the outcome of Amtech's decades of experience in motor control and automation.

The Low loss, High efficiency Industrial Grade New Series is designed to meet the ever increasing expectations of our customers; deliver highest performance, protection and energy saving without compromising the user friendliness.

Models:

400V : 1 to 2700 HP (0.75 to 2000 kW)

500V : 40 to 2500 HP (30 to 1800 kW)

600V : 50 to 2900 HP (37 to 2100 kW)

Features:

- Highly efficient 7th Generation IGBT and Capacitors
- Fully configurable digital and analog I/Os & functional safety function (STO)
- Wi-Fi and RS-485 Modbus communication as standard
- 128x64 Graphical LCD Display with white back light and RTC
- Easy to diagnose with diagnosis functions

Applications:

- Pumps, Blowers, Fans
- Agitators & Conveyors
- Compressors, Centrifuges
- Paper & Pulp
- Oil & Gas
- Mining



ADAPT SYSTEM PUMP JACK SOLUTION

Amtech Drives offers the ultimate solution in SRP (Sucker Rod Pump) control, the most common forms of reciprocating artificial lift system employed by Oil and Gas companies worldwide.

Amtech offers solutions in all the processes of Upstream, Midstream and Downstream in Oil & Gas industry.

Models:

400V : 5 to 100 HP (3.7 to 75 kW)

Features:

- Factory-tested Integration
- Simplified setup
- Smooth starting & operation of system
- Lower impact on piping/valve system, longer equipment life and less maintenance
- Unique algorithm for torque control and no need of braking resistors

Applications:

- Oil well pumpjack



ENGINEERED SYSTEMS

Our vertically integrated engineered systems assures seamless co-ordination between individual components in our complete packaged solutions.

The packages comprise VFD modules with customer specific switchgear & protection, enclosure requirements and cooling arrangements. The seamless integration guarantees that performance specifications are adhered to as per the ratings, enclosure types, environmental issues and power supply conditions.

Advantages:

- Global compliances UL, cUL, CSA and CE
- Normal duty & heavy duty ratings
- UL panel shop
- Energy efficient systems
- Can be built to your specification

Customized Applications:

- Bypass Solutions for Critical Applications
- Redundant System
- Low Harmonic Solutions

Specifications in this catalog are subject to change without notice.

CAT.NO. : ADI/OPTI-IB/04-26



Amtech
DRIVES

745 Trabert Ave NW
Atlanta, GA. 30318
Phone : (770) 8AMTECH
 : (770) 826-8324
E-mail : info@amtechdrives.com
URL : www.amtechdrives.com

